



**DIVISION NEWS**

2001 closed with a hectic three months in which the editors *time line* in the real world, intersected and impinged severely, with his fantasy world of volunteer work - where all things are possible. This is the only excuse I have for the lack of a Sept./Oct. issue of PCTimes, and should be taken as an apology by the membership. However, at the same time, I must admit to being completely 'underwhelmed' by the response to my call for submission of articles for "on the rocks" and "tales from swampy kitchens".

In the same breath , I must thank Rob Harrap for his article - it is more than timely for myself and others dealing with the new reality of computer generated, print on demand, attributed database, ..... driven map production. What ever happened to the pencil crayon?? As times change many a mapping geologist has moved into the world of cross border NATMAP (Lithoprobe, NSERC, etc) driven products on CD ROM were the 'discussions on a joint legend by two geologists is interesting, and for multi-organization multi-Ministry driven projects it can be a nightmare. I hope everyone enjoys Rob's thoughts on legend structure.

*Continued on page 2*

**ON THE ROCKS:**

**A Legend Language for Geologic Maps**

*Rob Harrap*

*Department of Geological Sciences*

*Queen's University, Kingston, Ontario.  
K7L 3N6. Harrap@geol.queensu.ca*

**Introduction**

Geology has always been an oddball science, part historical narrative, part cartographic exercise, part application area for the techniques pioneered in the other sciences. Perhaps as a result of its historical nature, tradition-bound methods are more common, and harder to dislodge, than in other sciences. And unlike the canonical sciences of physics and chemistry, geology suffers from a problem of the classical scientific method: geological studies cannot directly make use of the method of a constrained experiment where one variable in a system is systematically varied. Indeed, the biggest problem in geology is often to somehow arrive at an understanding of just what the controlling variables were in the first place.

If geology is a narrative, then geological maps are a tapestry woven by that narrative. Yet the maps are descriptive without really recounting the substantial component of a narrative: a sequence of events. Tradition lays out a framework for geological maps with the map itself, cartographic ornamentation such as scale bars and north arrows, and finally a legend. Legends as dictated by convention contribute little to the narrative, instead being a mere list of actors in the historical drama, albeit in a crude chronological order.

It is my contention that the component of geological maps most in need of revision in order to enhance our ability to tell geological stories and thus do solid geological mapping is the geological legend; in my view many of the difficulties in using maps, and especially in automating aspects of geologic map

*continued on page 3*

**INSIDE THIS ISSUE**

- 1
- 1 *On the Rocks: A Legend Language for Geologic Maps by: Rob Harrap*
- 2 *Comments from the editor*
- 3 *Tales from swampy kitchens*
- 10 *Wouter Bleeker - Howard Street Robinson Lecture Tour 2001*

# 1999-2000 G.A.C. Precambrian Division Executive and Council

## Chairperson: *Ric Syme*

Manitoba Industry Trade and Mines,  
Mineral Resources Division, Geological Survey,  
Suite 360, 1395 Ellice Ave.,  
Winnipeg, Manitoba, Canada R3G 3P2;  
Tel: (204) 945-6556 Fax: (204) 945-1406  
e-mail: [esyne@em.gov.mb.ca](mailto:esyne@em.gov.mb.ca)

## Past Chairperson: *Mike Easton*

Ministry of Northern Development & Mines  
Precambrian Geoscience Section, Ontario Geological Survey  
933 Ramsey Lake Road,  
Sudbury, Ontario, Canada P3E 6B5  
(705) 670-5995, Fax (705) 670-5905  
e-mail: [eastonrm@vianet.on.ca](mailto:eastonrm@vianet.on.ca)

## Vice Chairperson: *Tim Corkery*

Manitoba Industry Trade and Mines,  
Mineral Resources Division, Geological Survey,  
Suite 360, 1395 Ellice Ave.,  
Winnipeg, Manitoba, Canada R3G 3P2;  
Tel: (204) 945-6556 Fax: (204) 945-1406  
e-mail: [tcorkery@em.gov.mb.ca](mailto:tcorkery@em.gov.mb.ca)

## Secretary/Treasurer: *Shoufa Lin*

Department of Earth Sciences  
University of Waterloo  
200 University Avenue West  
Waterloo, Ontario, Canada N2L 3G1  
Tel: (519) 888-4567, ext. 6557 Fax: (519) 746-7484  
e-mail: [shoufa@sciborg.uwaterloo.ca](mailto:shoufa@sciborg.uwaterloo.ca)

## Councilors:

### *Lorne Ayers*

Dept. Of Geological Sciences  
University of Manitoba  
Winnipeg, Manitoba Canada  
R3T 2N2  
Phone: (204) 474 8857  
Fax: (204) 261-7581  
e-mail: [ld\\_ayres@umanitoba.ca](mailto:ld_ayres@umanitoba.ca)

### *Normond Goulet*

Université du Québec à Montréal  
Dépt. des Sciences de la Terre  
Succursale A, C. P. 8888  
Montréal, PQ H3C 3P8  
(514) 987-3375, Fax (514) 987-5782  
e-mail: [r27254@er.uqam.ca](mailto:r27254@er.uqam.ca)

### *Mike Easton*

Ministry of Northern Development & Mines  
Precambrian Geoscience Section,  
Ontario Geological Survey  
933 Ramsey Lake Road,  
Sudbury, Ontario, Canada P3E 6B5  
(705) 670-5995, Fax (705) 670-5905  
e-mail: [eastonrm@vianet.on.ca](mailto:eastonrm@vianet.on.ca)

### *John Percival*

Department of Natural Resources Canada,  
Geological Survey of Canada,  
601 Booth Street,  
Ottawa, ON K1A 0E8  
(613) 995-4723, Fax: (613) 995 9273  
e-mail: [jpercival@gsc.nrcan.gc.ca](mailto:jpercival@gsc.nrcan.gc.ca)

## COMMENTS FROM THE EDITOR

Precambrian Times will be published 3 times per year by the PreCambrian Division of the Geological Association of Canada (April/May, September/October and January/February). We are following the lead of MDD and it is hoped that future distribution will be primarily by PDF files that can be downloaded from a web site. An e-mail notice will be sent to all members giving the location and name of the file. For those without e-mail or web access (or who specifically request snail mail) we will print (black and white) and mail them a copy of the newsletter and any other pertinent communications.

## CONTRIBUTOR INFORMATION

Manuscripts should be submitted by e-mail in WORD or WP format. Photos and illustrations can be in black and white or colour and illustrations should be camera ready - because they will go in as they are - preferably in a CDR format (Corel 8 or less please). Note; the maximum file size for attachments is 4 MB.

Items dealing with division news, events, or meetings can be submitted by fax, post or e-mail.

## SUBMISSIONS

Tim Corkery (*Temporary Editor*)

Manitoba Industry Trade and Mines,  
Mineral Resources Division, Geological Survey,  
Suite 360, 1395 Ellice Ave.,

Winnipeg, Manitoba, Canada R3G 3P2;

Tel: 9(204) 945-6556 Fax: (204) 945-1406

e-mail: [tcorkery@em.gov.mb.ca](mailto:tcorkery@em.gov.mb.ca)

*continued from page 1*

The annual meeting of the Precambrian Division of GAC was held at Calgary 2000 and several items of note were dealt with.

- **Howard Street Robinson award:** first and foremost was the nomination of Wouter Bleeker as the Division's choice for the Howard Street Robinson award. The Robinson Fund Committee agreed unanimously and Wouter will be travelling the country from west to east in February and March.
- **Precambrian Division Medal:** a proposal for a Division Medal was received from Jérôme Remick and discussed at length. No final decision was made and further communication with the GAC council is needed to assess the desire and need for another GAC Sponsored medal. We will revisit this in ST. John's.
- **Precambrian Division sponsorship at GAC/MAC conferences:** A 'Precambrian minded' member of local organizing committees (LOC) should be approached to function as a contact with the Division during conference planning. This person can look out for appropriate of symposia and field trips that the Division could support or participate in.

# TALES FROM SWAMPY KITCHENS

## An Award is Born

Field trips are first and foremost, educational - right?. That is the premise (and for the employer the promise) and in most cases seeing is believing and getting right down and touching the rock is akin to finding the "holy grail" for the Rock Doctor. I know this having to see for yourself is true. My wife says its geological and often points out "You have to go see or touch everything for yourself. Can't you ever just take my word for it?" Well some times even seeing and describing the resulting features of an unobserved action can't provide any satisfying working models that will lead to a new paradigm. However, this banter may be misleading you, this story is not about unraveling one of the earth's great mysteries but rather an earthly event with few plausible explanations. It caused all 26 participants of the water borne amada, to spend several hours later - over a few brew - applying good scientific conjecture, piecing together the event. I'm not certain that the event was nearly as important as the brew.

Seven inflatables, with they're Mercs humming that deep throaty rumble in unison, all cruising in formation down the river. We were only about five or ten minutes into the day, and boy it looked like a good one. Warm sun on your back, the water sparkling clear and calm, and that cool crisp morning air promising a perfect northem day. One of those magnificent days we all dream about in February while planning the field trip onto a big lake. It was all too idyllic.

For my part, it really was all so well planned, and now for the prefect execution. With me, the field trip leader, in the front boat and an experienced man at the helm of the boat pulling up the rear. What could go wrong? Outboard motors can be temperamental but I'm a pretty fair mechanically and  
*continued on page 4*

## ON THE ROCKS: *continued from page 1*

analysis using geographic information systems (GIS) arise from the convention bound nature of legends. The specific improvement I propose is to replace list-style legends with diagrams that more clearly depict the historical, narrative aspect of geological mapping.

### Traditional Legends and Their Drawbacks

Geologic histories are stories about the evolution of an area, hopefully constrained by some real world observations, and compliant with extant geological theory (both abstract and analogical). A geologist is to some degree a detective, putting together a story that explains who the agents were, which props were relevant, and most importantly, the sequence of events. The normal result of this detective mission is a report and a map, with the story distributed between the two. To a trained eye, much of the story will be visible in the map - indeed, many of the formalisms on geologic maps are explicitly designed to convey either constraints or aspects of the history directly. Others are intended to demonstrate where ambiguity is present, at least in the spatial character of the map - witness specific line types for observed, inferred and assumed contacts on many maps. But some aspects of the story, especially timing issues, need to be dragged forth from the descriptive text or recreated using the map as a virtual field area and geologic knowledge as a guide.

For example, consider the map shown in Figure 1 - a trivial example, on first examination. Clearly a sandstone-shale sequence was faulted, tilted, and intruded by a granite. The stratigrapher reaches for the report to determine the nature of the units and stratigraphic contacts and which unit is in fact older. The structural geologist bemoans the lack of structural measurements and wonders about the attitude of the interfaces. The metamorphic petrologist envisages isograds from contact metamorphism. You

may also note, though, that the geologic history as described is not in fact obvious in the map without formal knowledge about geology, and even then is to some extent ambiguous. The relative order of faulting and intrusion is unclear without geologic knowledge. The order of faulting and regional tilting of the sequence is unclear. And perhaps the timing of the fault is not as well known as the map shows, for example the fault may cut the granite but with trivial offset in the map view. The answers to some of these questions are obvious with geologic knowledge, while the to others answers may lie in the report that accompanies the map. Other questions may in fact be unresolvable given the state of mapping. To a computer mapping system, even the basic elements of the story are cryptic: computers have no knowledge of geology to guide interpretation of histories from map geometry.

The legend as shown does by convention clarify matters somewhat: it intends to demonstrate that unit 1 is the oldest and unit 3 is the youngest. It does not aid in the details of timing of tilting and faulting, and the situation gets much worse for more complex maps with consequently more complex contact relations. List-style legends, on complex maps, are not particularly informative to a geologist (who could do almost as well with a text-only description of the units used in the map), and next to useless to automated analysis tools in a GIS.

### Diagrams and Formality

Human languages are notoriously ambiguous; this is a result of the relative and informal basis of words themselves and also of often unclear permutations that arise through syntax. Logic and mathematics, on the other hand, are unambiguous though often

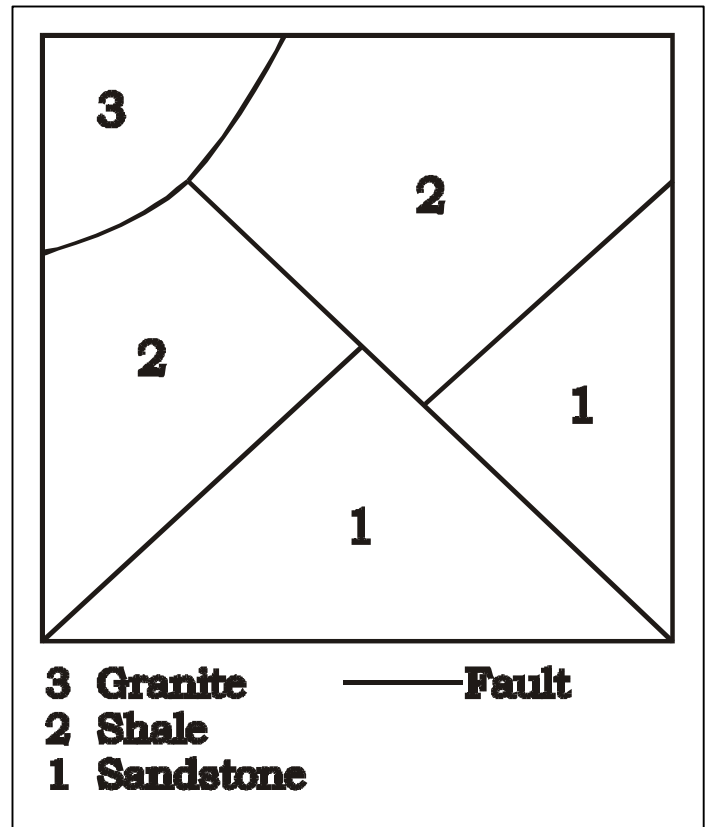

Figure 1 A simple geologic map with typical legend. Note that the fault is explicitly identified but the type of other contacts is assumed.

had personally checked out and tuned all the motors the day before, but even so I was keeping watch to make sure everyone was keeping up. No reefs in this mud banked river, just cruise on out to the lake. *Continued on page 4*

Then I noticed that the last boat wasn't keeping up, in fact it looked to be dead in the water. Signaled all to stop, I then sent Malcolm back to find out what the problem was. He did a quick jaunt down the line and boarded the drifting dingy. As I watched him getting back into his boat I could see he was a bit unstable and holding a stick or something. He sped back up to my boat and announced, "that Achilles seems to have lost part of its motor."

"What part?" I said, "we put them all on yesterday, checked them, and tightened em up. It doesn't make sense, what the . . . fell off?"

"It's much easier to show you what's left." He said laughing hysterically, as he held up the rubber grip from throttle handle and ? "aluminium tube, nothing else, just the throttle handle. And continued "no there's nothing wrong with the transom, boat or occupants - just not much motor left. He had a death grip on this bit - it wasn't going to get away the way the rest did. However, he continued " the gas line goes straight into the lake and we're pretty sure it's not running. At least we can't hear it and there aren't any bubbles."

Well after we put the boat ashore, divided up the people in the remaining boats and a little over-loaded we set out again. Needless to say it soon clouded over, before noon the wind came up as did 5 foot waves and by 2:30 it was raining. Some people still swear there was sleet in it, but I don't believe them.

Back in the lodgings that night discussion of how a motor falls off of a boat in mirror flat water at 35 km/hr without a mark on the boat, was the topic of discussion. No one in the boat seems to have a clear recollection the event and the helmsman is keeping quiet!

This was the founding of an annual award for our group. To be presented for the most outrageous event to happen in the field each year. Some people hide from it, but serendipity will catch us all in turn.

### ON THE ROCKS: *continued from page 3*

impenetrable to mere mortals (or even geologists...).

Formality, the requirement that a system use unambiguous rules and clearly defined terms, is a good thing to strive for if information is to be manipulated not only by humans but also by computers. All of the computer languages so far implemented are formal, and progress in computer manipulation of human language has been very slow (c.f. Allen, 1994). The predicate calculus is a good example of a completely formal language for making statements about the world, widely used in artificial intelligence and one of the corner stones of the study of knowledge representation (Sowa, 2000). Alas, the result is virtually unreadable without advanced training, hardly something to recommend it for a place on the margins of geologic maps and inside geologic reports.

Enter diagrams. Humans seem naturally attuned to processing information in a diagrammatic form – witness the use of maps for geology in the first place – and moreover humans easily learn to use even complex diagrams representing sophisticated concepts. The average geology student, for example, typically has far more trouble learning to identify rock types than to plot the rock characteristics on graphs. This may be in part cognitive affinity and in part cultural artifact – after all, the basics of graphs and diagrams are taught in public school – but this is immaterial. Diagrammatic methods work, are easy to master, and if well designed, are self explanatory (c.f. Tufte, 1990). Finally, it is simple to make diagrams for representing knowledge that are formal and still simple to use. A properly built graphical language has all the power of logic and mathematics without the headaches (e.g. Howson, 1997).

### Applied Graphical Languages

Scientists have been using graphic representations of knowledge for a long time. Certainly mathematical knowledge has appeared in graphic form for several hundred years. Logic, and the predicate calculus in particular, was translated into diagram form in the 1800's by Gottlob Frege (Frege, 1897). In fact, Frege devised his diagrammatic notation immediately after devising an early form of the predicate calculus specifically to clarify and communicate complex statements.

More commonplace applications of formal diagrammatic languages include conceptual diagrams in business (Axelrod, 1976), artificial intelligence research (Quillian, 1968), philosophy of science (Toulmin, 1958; Thagard, 1992) and the like. In geology, diagrams

specifically designed to represent aspects of geologic histories appear to derive from cladistics, the study of genetic diagrams, and early examples include the "Mongergrams" used in Cordilleran terrane analysis (Monger et al, 1982) and now commonly used to depict tectonic accretion sequences during the evolution of continents.

Some of these languages are truly formal, and some are less well structured but nonetheless effective in translating complex stories into understandable form. I will concentrate on a formal language to enhance the use of the result both for humans and especially for use in Geographic Information Systems.

### A Basis for a Legend Language

If a language is to tell stories, it needs the equivalent of nouns (to name things) and verbs (to show relations between them). To be formal, the nouns need to be unambiguous and the verbs need to be both consistent and conserve meaning during manipulations. In mathematics, the value of basic operations (like +, -, etc.) is conserved, else chains of math operations would fail to produce consistent results. Much more could be said of this issue of formality, but for our purposes this is more than enough.

Examples of geologic items that need to be represented on a legend include geologic units, faults, unconformities, and the like. Of these, in a traditional map at least, units are clearly nouns and faults and unconformities, verbs. There is an additional necessary verb that we normally take for granted: contact type in the trivial case, such as intrusive contacts around intrusions or depositional contacts between sedimentary units. Clearly, in detail geology is completely dynamic (or verb-like) at some level because sedimentary units for example are the result of processes acting on finer-scale nouns (e.g. clastic fragments). We will sweep this level of detail under the carpet and treat units as named, noun-like things and concentrate on the dynamic, story-building properties of contact relations. In this first attempt at a Legend Language I will only address the narrative as it reflects, or is reflected in, geologic contacts. Geologic events such as regional tilting events that do not directly contribute to contact types will be disregarded – they are neither nouns nor verbs. These events may of course be placed in an LL as passive symbols to complete the narrative without difficulty.

Table 1 shows the simple noun-and-verb vocabulary I will use for the examples that follow. It should be clear by the end of this paper that adding new nouns and verbs to this list would be straightforward. The table also shows abbreviations for the verbs, which are used in the sketches that follow.

<u>Item</u>	<u>Type</u>	<u>Abbreviation</u>
Depositional Contact	Verb	C
Unconformable Contact	Verb	U
Intrusive Contact	Verb	I
Fault (Contact)	Verb	F
Geologic Unit	Noun	(number)

**Table 1** Geologic terms used in the Legend Language and their short forms used in the diagrams that follow.

### Demonstration 1: Units Faulted

Figure 2a shows the simple case of a pair of units faulted after deposition and regional tilting. As a start, Figure 2b expresses the legend for this map in two forms: traditional, and as a graphical legend form (hereafter called Legend Language form, or LL). The obvious first difference is that the LL explicitly makes contacts between units part of the story. It is also formal, and furthermore can be manipulated to produce some useful results, especially using GIS technology were the manipulations can be automated.

Figure 3 shows an expansion of the LL graph from Figure 2b. The rules used were simply:

- (1) Units occurring in sequence and in depositional contact can be in depositional contact with each other only if directly joined by the -C- label. This is trivially true.
- (2) Faults can be expanded and allow all units in earlier portions of the LL to be in fault contact with any units in that same package. This is a special case of a more general rule for faulting.

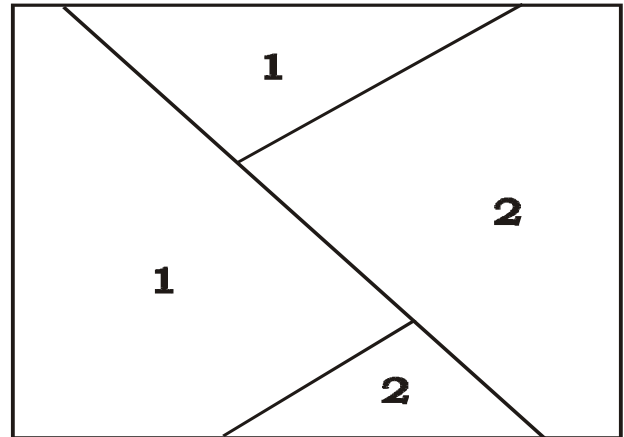

**2 Shale**  
**1 Sandstone**

Figure 2a: A simple geologic map showing fault offset of a simple stratigraphic sequence. Note that here I have explicitly labeled the fault as such. For the Legend Language to work in a GIS, contact types must be explicitly labeled.

#### Traditional Legend

2 Shale  
1 Sandstone

#### Legend Language

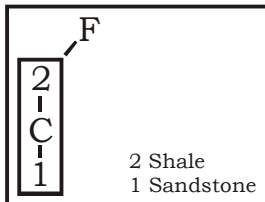

Figure 2b: A traditional legend compared to the Legend Language depiction for the map shown in Figure 2a. Note that Figure 2b 1 the LL contains the unit names but much more: the sequences are identified by boxed groups and the fault is demonstrated to act upon all earlier nouns and verbs. The offset in the F label is not strictly required in this case, but as we will see in a later example, is necessary for more complex examples.

- (3) Fault contacts found using (2) postdate all contacts in the precursor packages (again, to a geologist trivially true).

The Legend Language version can be read as follows: A fault affects a preexisting package of rocks consisting of units (2) and (1) which are in conformable contact. The 'package' is implied both by the offset in the fault label, and also because fault operators in the Legend Language always affect all preexisting rock masses collectively.

The first representation in Figure 3 is human readable, and if that

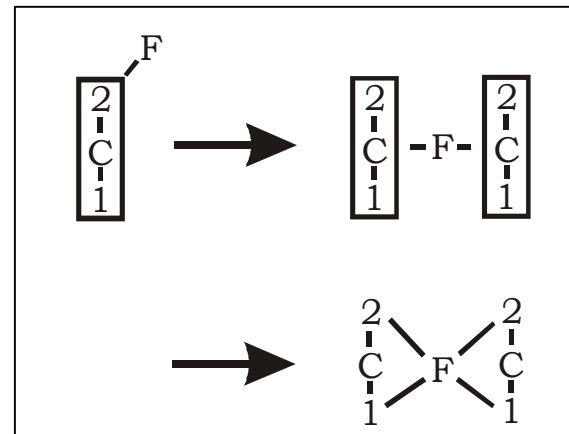
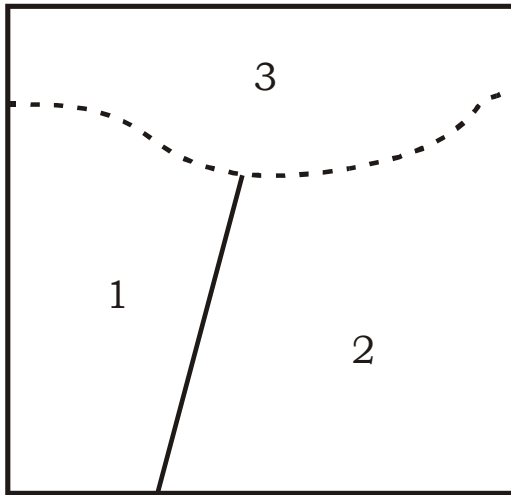

Figure 3: The Legend Language depiction from 2b can be expanded to show all of the permissible contact types on the map. The Fault verb has the effect of copying the earlier sequence and allowing the two resulting sequences to be in fault contact. Of course, many of the permissible contact relations will not actually occur on the map

was our only concern we could stop right there. We would then have a start at a rigorous mini-language for legends that explicitly names all events in a geologic history in a formal way. This would be very useful for recounting geological narratives in its own right.

The second and third representations shown in Figure 3 are equivalent to the first but demonstrate the hidden power of the formal representation of a legend. These graphs show all of the contact relations that are permissible on the geologic map if the legend is in fact correct. As the legend is a formal and complete representation of the

geologic history of the area from the point of view of contact relations, then contact relations on the map that are not permissible from the graph expansion are either invalid on the map or illustrate a problem with the geological history, or both. Much as math and logic allow one to locate errors in numeric and logical arguments, the LL allows us to find errors in geologic histories and/or maps. And although there is this expanded version of the LL that is much more complex than a traditional legend, the diagrammatic nature of the displayed version of the Legend Language shields us from the underlying complexity.



3 Conglomerate  
2 Shale  
1 Sandstone

Figure 4a: A geologic map with two units in conformable contact, unconformably overlain by a third unit. Note that again the contact types are labeled.

**Demonstration 2: Units with Unconformity.**

Figure 4a shows a simple map with three units, one of which unconformably overlies the others. The legend language version is shown and expanded in Figure 4b to show permissible contact types. In this case the rule applied is:

- (4) the unit immediately above an unconformity may be in unconformable contact with any unit in the older succession.

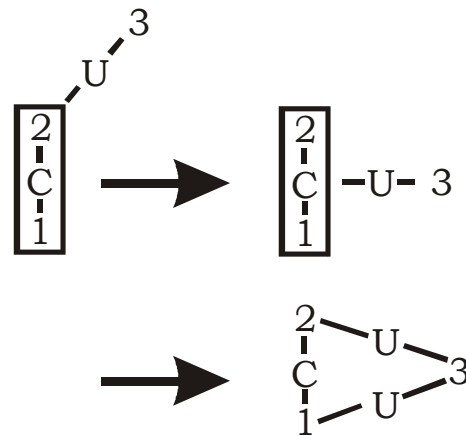
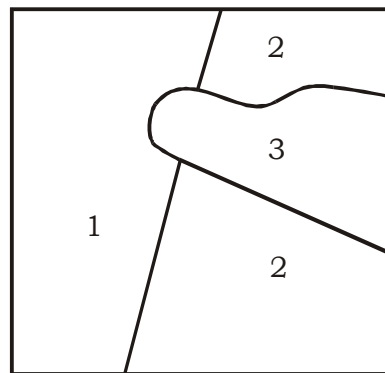

Figure 4b: The history portion of the LL corresponding to Figure 4a and expanded to show permissible contact types.

**Demonstration 3: Units with Intrusions.**

A simple case of intrusion is shown in Figure 5a, with the corresponding legend language and its expansion shown in Figure 5b. Note that this is identical in behavior to an unconformity. A potential problem arises if units on the map include contact metamorphic domains, although this can be handled if necessary.

- (5) a unit intruding a succession may be in intrusive contact with any unit in that succession.



3 Granite  
2 Shale  
1 Sandstone

Figure 5a : geologic map with an intrusion cutting an older sequence of 2 units.

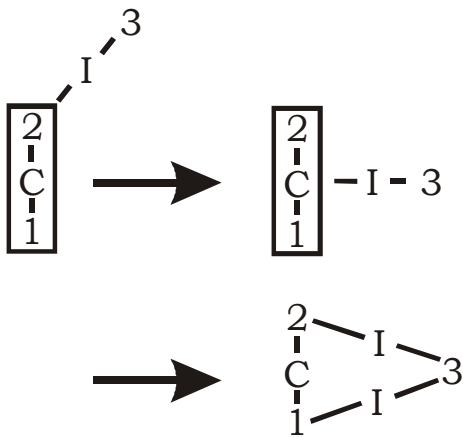

Figure 5b The history portion of the LL from Figure 5a expanded to show permissible contact types. Note that the verb for Intrusion

#### Demonstration 4: Faulting with Suspect Terranes

In some cases the geologic sequences that are placed in contact by a fault are, at the scale of mapping, different. In this case the legend language representation makes the two successions distinct packages as shown in figure 6a. Note that this situation is normal in most complex geologic terranes.

A more general fault rule than the one given in (2) above can then be described:

(2b) Faults affect two packages, allowing all members of each package to be in fault contact with members of the other package. Faults within one package operate by generating two identical packages and then following this rule.

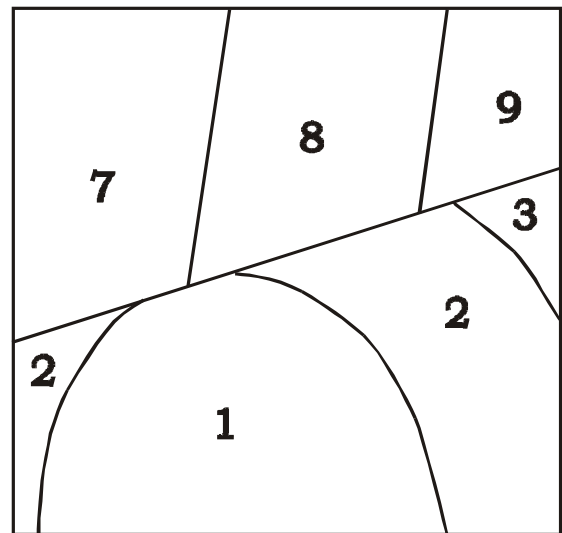

**3 Marble**                      **9 Dolomite**  
**2 Metapelite**                **8 Limestone**  
**1 Quartzite**                    **7 Sandstone**

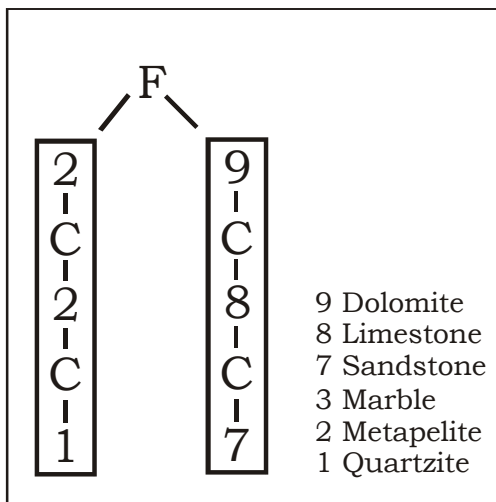
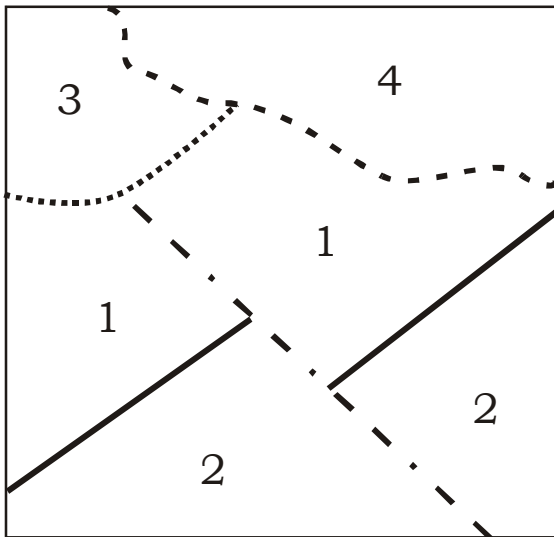

Figure 6a: A more complex geologic map with two 'suspect terranes' in contact across a fault. Note that the geologic history of the two blocks before faulting is different. The LL as developed here only includes verbs strictly necessary for handling contact types. A 'folding' operator could easily be added to place the folding in context, but it would be a simple passive marker in the process of expanding the Legend Language to show permissible contact types.

Figure 6b: The LL corresponding to the geologic history of map 6a. Note that the offset in the Fault operator here makes the LL clearer.

### Demonstration 5: A Complex Geologic Map

A more realistic map is shown in Figure 7a, which can be thought of as a detail of a small portion of a large regional map. Note that here we have many verbs operating on one set of early nouns (units 1, 2) and less so on later nouns (units 3, 4) because these later nouns either postdate events or are dynamically related to them. The simple legend language rendition of the geologic history is shown in Figure 7b. A first step in expansion is shown in Figure 7c. Note that there is an implied nesting rule here, that simply says that the fault affects the rocks first, then the intrusion affects the rocks and the fault (which moves from being only a verb to being a verb and noun), then the area is eroded and a unit is placed on top. From bottom to top the Legend Language is a narrative describing the geologic history of the area.



- 4 Conglomerate
- 3 Gabbro
- 2 Basalt
- 1 Iron Fm

The LL grows more complex on further expansion (though computers can easily handle this type of formal complexity), and the final result is distilled into table form in Table 2. As the table is symmetric, only the upper half need be filled in. We can now compare the actual contacts seen on the map and indeed see that the map and geologic history are consistent.

	1	2	3	4
1	F	F,C	I	U
2			I	U
3			-no-	U
4				-no-

**Table 2- Permissible contact relationships in the map shown in Figure 7. Note that the table is symmetric and redundant cells are left blank here. This table may be constructed from the LL shown in Figure 7b in a completely unambiguous manner.**

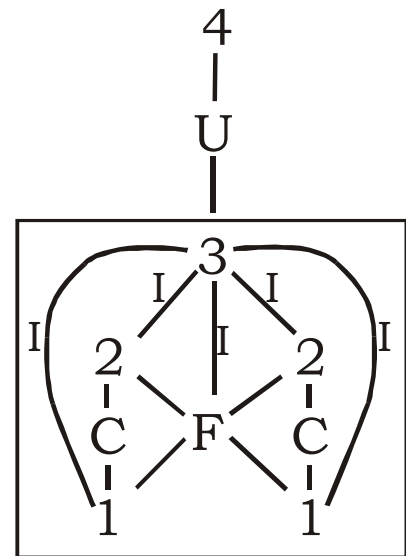
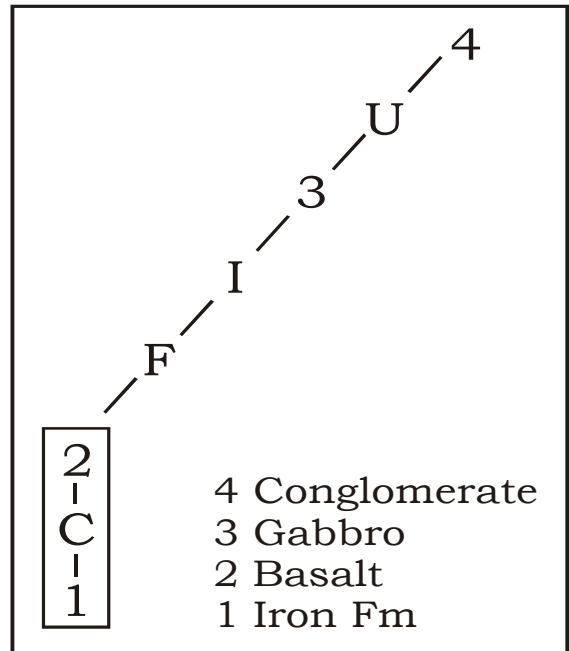

This same consistency test can be done even if there are thousands or millions of polygons on a map, as is the case for regional geologic maps where internal inconsistencies are most likely to go unnoticed. And finally, a very complex geologic history can be handled (such as the narrative describing the evolution of a complex Archean domain) and represented, although in this case the expansion of the LL is best handled by computer.

In real geologic maps, there may be multiple fault and multiple intrusive events. The LL can handle these either by naming each with a unique subscript or label, or alternatively by simply applying the rules of graph expansion rigorously. In the case where units need to be checked for contact relations dependent on specific age faults, the labeling method is necessary. In most maps, the added complexity is unwarranted.

## Development of GIS Legend Language Tools

As a simple exercise in GIS programming, the Legend Language can be implemented directly in software. A simple version of the LL was programmed in the ArcView environment using the Avenue object-oriented programming language (ESRI, 1996). The scripted tool was then applied to a large dataset from the Abitibi Greenstone Belt with various interpretations of a geologic history legend, and inconsistencies between the history and map were flagged consistently (Ross, Pers. Comm., 1998). The script offers a simple way to test even large maps for internal consistency, although further development of the tool is required to directly expand Legend graphs.

## Future Direction

GIS tools for geologists until now have been aimed largely at field data capture (Brodaric, Harrap and Lemkow, in press) and 3d visualization, as well as countless specialized tools for producing geologic charts. The fundamental limit on the use of GIS for geologic analysis has become the problem of inconsistency in large geoscience datasets, both at the level of maps and at the more daunting level of geologic field observation integration. The problem includes geologic history differences such as those tackled herein, and also differences that arise through terminology and matter of scale (c.f. Coleman-Sadd et al., 1996). These problems, as well as the overarching problem of consistent data storage, are currently being addressed through such initiatives as the North American Data Model (Johnson et al, 1999). It is my view that these initiatives are useful, but run the risk of proposing solutions that overwhelm the geologist with technical requirements.

The Legend Language is an attempt to give geologists a tool that, even without GIS and databases, adds value to geologic maps: LL's make geologic stories explicit. The expansions and consistency tools discussed can be made to operate completely in the background – the geologist sees only the graph form. I hope that other tool developers bear in mind that tools must be intuitive to their audience, and that there is an extensive literature on how to achieve this (c.f. Norman, 1993).

## Conclusions

Humans understand diagrams intuitively, and as a result a wide variety of visual tools are used in everyday life. Computers, on the other hand, operate in a formal mode more akin to logic than to human language. The Legend Language approach is intended to bridge the gap between computer and geologist using a formal yet visual language, which helps us make our ideas

clear and provides a foundation for tools that greatly enhance our ability to build and edit geologic maps.

## Acknowledgements

Thanks to Dave Love and Herb Helmstaedt for critical reviews of this paper. The research for this paper was funded in part by the Ontario Geological Survey and in part by Lithoprobe. Boyan Brodaric posed the original question that this paper seeks to answer: how do we represent geologic histories in a GIS.

## References

- Allen, J. 1994 Natural Language Understanding 2ed. Benjamin/Cummings Pub. Co., Redwood City, CA.
- Axelrod, R. 1976 The Structure of Decision. Princeton University Press, Princeton N.J.
- Brodaric, B., Harrap, R.M. and Lemkow, D. in press. FieldLog 3 – a System for Capturing Field Data. Geol. Surv. Can. Open File, in press.
- Colman-Sadd, S.P., Ash, J.S., Hayes, J.P., Nolan, L.W. 1996 Management of Geological Map Units in a Geographic Information System. Current Research, Newfoundland Department of Natural Resources, vol 96-1. p. 227-251
- ESRI Inc. 1996 Using Avenue: Customization and Application Development for ArcView GIS. Environmental Systems Research Institute.
- Frege, G. 1879 Begriffsschrift, eine der arithmetischen nachgebildete Formelsprache des reinen Denkens. Halle, Berlin. Translated in van Heijenoort, J. ed, 1967. From Frege to Godel: A Source Book in Mathematical Logic, 1879-1931. Harvard University Press, Cambridge, Mass.
- Howson, C. 1997 Logic With Trees – An Introduction to Symbolic Logic. Routledge, New York, N.Y.
- Johnson, B.R., Brodaric, B., Raines, G.L, Hastings, J.T., Wahl, R. 1999 Digital Geologic Map Data Model v. 4.3. Web Document, <http://geology.usgs.gov/dm/>
- Monger, J.W.H., Price, R.A., Tempelman-Kluit, D.J. 1982 Tectonic accretion and the origin of the two major metamorphic and plutonic belts in the Canadian Cordillera. *Geology*, 10, 70-75.
- Norman, D.A. 1993 Things That Make Us Smart: Defending Human Attributes in the Age of the Machine. Addison-Wesley, Reading, Mass.
- Quillian, M.R. 1968 Semantic Memory. In *Semantic Information Processing*, M. Minsky ed., MIT Press, Cambridge, Mass. P. 216-270.
- Sowa, J. 2000 Knowledge Representation: Logical, Philosophical, and Computational Foundations, Brooks Cole Publishing Co., Pacific Grove, CA.
- Thagard, P. 1992 Conceptual Revolutions. Princeton University Press, Princeton, N.J.
- Toulmin, S. 1958 The Uses of Arguments. Cambridge University Press, Cambridge, U.K.
- Tufte, E.R. 1990 Envisioning Information. Graphics Press, Cheshire, Conn.



# H.S. Robinson Distinguished Lecture Tour 2000-2001

## Dr. Wouter Bleeker

Continental Geoscience Division  
Geological Survey of Canada

### Archean cratons of Laurentia and the search for early supercratons

#### Abstract:

Laurentia is cored by a collage of six or seven Archean cratons welded together during the Paleoproterozoic era and exposures of a subset of these dominate the geology of the Canadian Shield. As Archean cratonic margins typically form lower plates in the Proterozoic orogens, the overall contribution of Archean crust to Laurentia is even more impressive. To further our understanding of the cratons and the Archean in general it is important to compare and contrast their evolutions and ask questions such as: Where did they come from? Did some of them share a history prior to early Proterozoic break-up and dispersal? Or at earlier times? Perhaps the best known cratons of Laurentia are the Superior Province and the Slave Province, respectively, and several lines of evidence suggest that these two danced to a different tune during the ca. 2.7 Ga global tectonic cycle, thus calling for the existence of at least

two (and probably several more) distinct 'supercratons' at the close of the Archean. The geology of the Slave craton is now well enough documented and sufficiently diagnostic and homogeneous that we have a realistic chance of recognizing rifted and drifted fragments among the 25-30 Archean cratons around the globe. An important correlation tool will be a comparison of Mesoarchean basement complexes and their thin but diagnostic cover sequences.